



# Council Agenda Report

**From:** Ditas Esperanza, P.E.  
**Subject:** Urban Greening Grant Program  
**Date:** February 21, 2017

---

## Facts

1. The California Natural Resources Agency has issued a "call for projects" to municipalities, for an Urban Greening Grant Program.
2. The Urban Greening Program is funded by the Greenhouse Gas Reduction fund, and will fund projects that transform the existing environment into places that are more sustainable, enjoyable, and effective in creating healthy and vibrant communities. That specifically includes adding advanced stormwater treatment. Currently, \$80 million dollars is available for distribution.
3. The Grant is quite competitive and projects will need to hit a majority of the required criteria to be successful.
4. City staff has analyzed various options, believes that we can be competitive for the right project, and has prepared a concept plan for improving 8<sup>th</sup> Street from Pine to Oak Street (see Attachment 2).

## Options

1. Do nothing.
2. Direct staff to apply for the Urban Greening Grant, to improve 8<sup>th</sup> Street from Pine to Oak Street.
3. Direct staff to identify a different project to apply for the Urban Greening Grant.

## Analysis and Conclusions

1. If the City Council chooses not to apply for the Grant, there would be less opportunity to improve 8<sup>th</sup> Street.
2. In order to be successful in receiving a Grant, the City must demonstrate that the project meets the following criteria:
  - Reduction of Greenhouse Gas Emissions
    - Demonstrated by proposing to plant 35 street trees.
    - Energy use reduced from tree shade.
    - Provides reduced vehicles traveled through improved pedestrian mobility (new sidewalks, ADA ramps, curb extensions).
    - Provide enhanced bicycle mobility (Class III).
    - Provide enhanced multimodal access to Downtown and the Transit Center
  - Project enhances green spaces and uses systems to mimic natural systems for multiple benefits
    - Incorporates bio-retention swales, bio-filtration and permeable pavers to infiltrate stormwater, and reduce velocities of run-off; percolates groundwater.
    - Provides greening of a public street with reduced asphalt paving.
    - Includes stormwater mitigation by using permeable pavers and bio-retention planters.
  - Disadvantaged Community
    - Project is likely to support economic development for the immediate area, as identified in the California Department of Water Resources Mapping Tool, as a Disadvantaged Community.

- Organizational Capacity
  - Proven record that the City has delivered multimillion dollar Grant funded projects successfully.
- Additional points that the City can receive
  - 8<sup>th</sup> Street is within the City's Downtown Paso Robles Watershed Plan, as a proposed stormwater management facility.
  - 8<sup>th</sup> Street provides enhancement within the Downtown Commercial District.
  - City to provide a 5% match to the Grant.
  - Adds approximately 30-35 parking (angled) spaces, to the Downtown area.

**Fiscal Impact**

The requested grant amount \$1,800,000. The City would provide a 5% match for a total Project budget of \$1,890,000. The City's matching funds would come from the General Fund (Supplemental Sales Tax).

**Recommendation**

Approve Resolution No. 2017-XXX, authorizing staff to apply for an Urban Greening Grant for 8<sup>th</sup> Street from Pine to Oak Street.

**Attachments**

1. Resolution No. 2017-XXX
2. Concept Plan for 8<sup>th</sup> Street (plan view and artist renderings)

RESOLUTION NO. 17-XXX

RESOLUTION OF THE CITY COUNCIL OF THE CITY OF EL PASO DE ROBLES APPROVING THE APPLICATION FOR GRANT FUNDS FOR CALIFORNIA CLIMATE INVESTMENTS URBAN GREENING PROGRAM

WHEREAS, the Legislature and Governor of the State of California have provided funds for the program shown above; and

WHEREAS, the California Natural Resources Agency has been delegated the responsibility for the administration of this grant program, establishing necessary procedures; and

WHEREAS, said procedures established by the California Natural Resources Agency require a resolution certifying the approval of application(s) by each Applicant's governing board before submission of said application(s) to the State; and

WHEREAS, the City, if selected, will enter into an agreement with the State of California to carry out the Project.

NOW, THEREFORE, THE CITY COUNCIL OF THE CITY OF EL PASO DE ROBLES DOES HEREBY RESOLVE AS FOLLOWS:

Section 1. All of the above recitals are true and correct and incorporated herein by reference.

Section 2. The City Council hereby approves the following procedures regarding the application of an Urban Greening Grant Program:

- a) Approves the filing of an application for the 8<sup>th</sup> Street Project, from Pine to Oak Street; and
- b) Certifies that applicant understands the assurances and certification in the application, and
- c) Certifies that applicant or title holder will have sufficient funds to operate and maintain the project consistent with the land tenure requirements; or will secure the resources to do so, and
- d) Certifies that it will comply with the provisions of Section 1771.5 of the State Labor Code, and
- e) If applicable, certifies that the project will comply with any laws and regulations including, but not limited to, legal requirements for building codes, health and safety codes, disabled access laws, environmental laws and, that prior to commencement of construction, all applicable permits will have been obtained, and
- f) Certifies that applicant will work towards the Governor's State Planning Priorities intended to promote equity, strengthen the economy, protect the environment, and promote public health and safety as included in Government Code Section 65041.1, and
- g) Appoints the City Manager, as agent to conduct all negotiations, execute and submit all documents including, but not limited to applications, agreements, payment requests and so on, which may be necessary for the completion of the aforementioned project(s).

APPROVED this \_\_\_\_ day of \_\_\_\_\_, 20\_\_, by the following vote:

AYES:  
NOES:  
ABSENT:  
ABSTAIN:

\_\_\_\_\_  
Steven W. Martin, Mayor

ATTEST:

\_\_\_\_\_  
Kristen L. Buxkemper, Deputy City Clerk

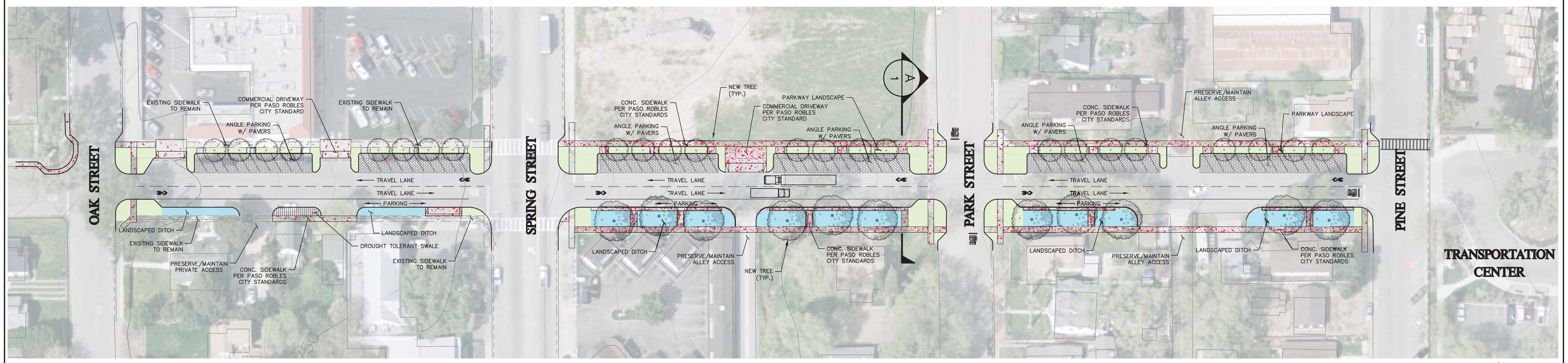

8TH STREET – PLAN VIEW

SCALE HORIZ 1"=40'

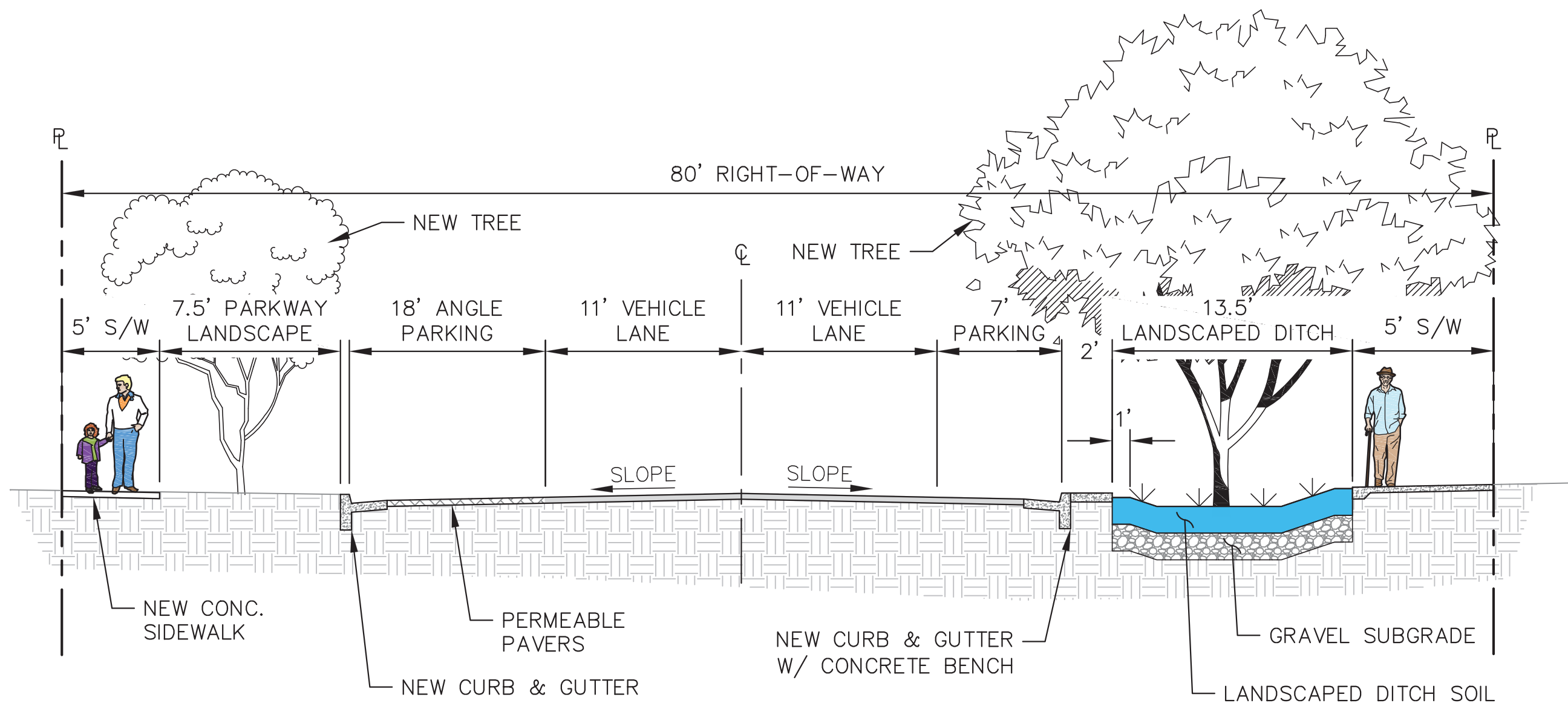

SECTION A-A

NO TO SCALE

**LEGEND**

- CONCRETE
- LANDSCAPED DITCH
- DROUGHT TOLERANT LANDSCAPE
- DROUGHT TOLERANT SWALE
- PERMEABLE PAVERS

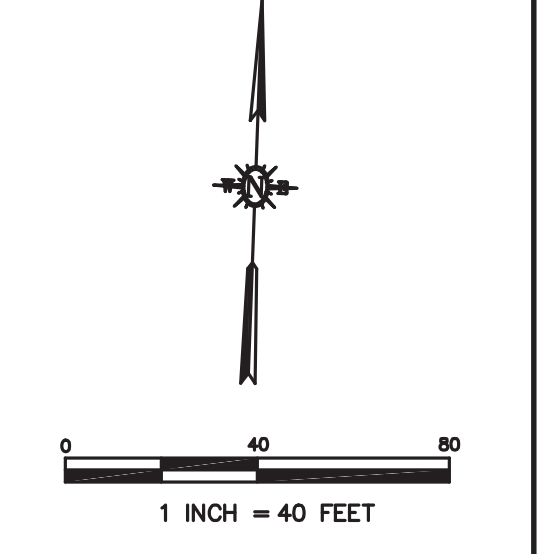

REV. NO	DATE	REVISED	DESTROY ALL PRINTS BEARING EARLIER DATE	REV. BY	CKD. BY	APRD BY

1050 Southwood Drive  
San Luis Obispo, CA 93401  
P 805.544.7407 F 805.544.3863

THESE DRAWINGS ARE INSTRUMENTS OF SERVICE AND ARE THE PROPERTY OF CANNON. ALL DESIGN AND INFORMATION ON THESE DRAWINGS ARE FOR USE OF THE SPECIFIED PROJECT AND SHALL NOT BE USED OTHERWISE OR REPRODUCED WITHOUT THE EXPRESSED WRITTEN PERMISSION OF CANNON.

URBAN GREENING GRANT  
8TH STREET IMPROVEMENTS  
CONCEPT DESIGN EXHIBIT

CITY OF PASO ROBLES, CA

DRAWN BY JMD	DATE 2017-02-10	CA JOB NO. 130723
CHECKED BY KK & LK	SCALE 1" = 40'	SHEET 1 OF 2



EXISTING CONDITION

AFTER IMPROVEMENTS





EXISTING CONDITION

AFTER IMPROVEMENTS

