

TO: James L. App, City Manager
FROM: Jim Throop, Administrative Services Director
SUBJECT: Transit Bus Purchase
DATE: December 6, 2011

NEEDS: For the City Council to consider the purchase of a new bus for transit.

FACTS:

1. The vehicles in the transit fleet are projected to provide 7 years of service, and then be replaced by newly purchased vehicles.
2. Several vehicles in the Paso Express fleet have exceeded the seven year span; however, due to reductions in transit funding, it has not been possible to replace these vehicles. Older vehicles are being kept in the fleet in order to have adequate spares to meet transit demands when other vehicles are out of service for mechanical repair, which, due to the aging of the fleet, has been occurring with increasing frequency.
3. Maintenance costs alone, actual repairs to the buses, were over \$200,000 for FY 2011.
4. The maintenance costs for transit vehicles have continued to rise as the fleet ages, and will likely continue to do so until newer vehicles are added to the fleet. Also, having older vehicle in the fleet makes meeting the reductions in vehicle emissions mandated by the California Air Resources Board (CARB) more difficult.
5. Funding for vehicle replacement was sought through the state Public Transit Modernization, Improvement, and Service Enhancement Account (PTMISEA), and approximately \$150,000 of this funding, after significant delays due to state budget constraints, has been received, enabling the purchase of a new transit vehicle to proceed.
6. Purchasing new transit vehicles through the State Contract (now the 'Consortium') has been done previously, and is planned for this purchase. Use of the consortium streamlines the procurement process and insures competitive pricing.
7. Adding a 30-passenger vehicle to the fleet, for use on the fixed routes, would have the greatest impact on transit operations. After review of the available models, a Ford F-550 cutaway vehicle has been selected. The cost of this vehicle, with needed equipment and all other costs (taxes, delivery, etc.) will be approximately \$128,000. The specifications for this vehicle are included in Attachment 1.

**ANALYSIS &
CONCLUSION:**

The City has adopted vehicle replacement policies based on the useful life of the equipment. Several transit vehicles have exceeded their useful life, but have not been replaced due to limited available funding for new vehicle purchases. This purchase will be paid for by funds from the State's PTMISEA grant program. Any additional PTMISEA grant funds left over after this purchase can be saved and used for future vehicle purchases through additional grants from the PTMISEA. The Transit fund has applied for additional grants, but due to the state's economy, the funding is unlikely to happen soon. Replacement of the transit vehicle will also help continue to meet California Air Resources Board requirements for emissions reduction.

**FISCAL
IMPACT:**

The full price of the planned vehicle purchase (approximately \$128,000) will be paid for through the State PTMISEA grant program. Neither the General Fund nor the Transit fund will be impacted by this purchase. The City's Transit Fund may even experience a slight savings from reduced maintenance costs after the addition of the new vehicle to the fleet.

OPTIONS:

- a. Adopt Resolution No. 11-xxx authorizing the purchase of the new vehicle, or
- b. Amend, modify, or reject the above option.

ATTACHMENTS:

Attachment 1: Vehicle Specifications

Attachment 2: Resolution

Attachment 1 – Vehicle specifications



Creative Bus Sales

Revised - Paratransit Bus Proposal

City of Paso Robles

EIDorado National – Aero Elite 320 Ford F-550
(23) Passengers + (2) Wheelchairs or (29) Passengers (Front Lift)

PUBLIC AGENCY - MBTA/CalACT Cooperative Bid
November 18th, 2011

The Vehicle(s) To Be Provided In Accordance With Request For Proposals MBTA/CalACT RFP #10-01. The Following Changes Are Incorporated To The City of Paso Robles.

PRICE CALCULATION: CalACT Class E – 32' Ford F-550 (EIDorado Aero-Elite 320) \$ 73,619.00

Ford F-550 – Ford 6.7 Liter Powerstroke Diesel – Automatic Transmission - Front Ricon Wheelchair Lift Location - (2) Total ADA Positions - Gray Altro Flooring – D-90 Seating - 225 Amp Alternator

Options:

(Add) – 6.7 Liter Powerstroke Turbo Diesel	8,862.00
(Add) – Mor/Ryde Suspension	1,150.00
(Add) – (3) Freedman Double Foldaway Seats – (\$975.00 each)	2,925.00
(Add) – Roof Hatch	495.00
(Add) – Driveline Brake Retarder	7,450.00
(Add) – Thermo King S40-II w/Roof Top Condensers	5,200.00
(Add) – All Exterior Dialight LED Lighting	655.00
(Add) – Twin Vision Electronic Signs (Front/Side) (Large Signs)	7,500.00
(Add) – “Stop Request” System	995.00
(Add) – Rear Tow Hooks	75.00
(Add) – PA System & External Speaker	350.00
(Add) – Hubodometer	90.00
(Add) – Diamond SV Farebox w/2 Vaults	1,450.00
(Add) – Lift Pad Kit	350.00
(Add) – Special Paint and Graphics	3,250.00
(Add) – Front Bike Rack w/Removable Hitch	2,275.00
(Add) – Ford Shop Manuals	350.00
(Add) – AM/CM/CD w/MP3 – 4 Speakers	655.00

Vehicle Price	\$ 73,619.00
Option Total	44,077.00
Document Prep Fee	55.00
Vehicle Sub-Total	117,751.00
Sales Tax (\$ 107,326.00) x 7.75%	8,317.77
CalACT Procurement Fee	1,766.27
California Tire Fee	12.25
Vehicle Total – Each (Delivered)	\$ 127,847.29

13501 Benson Avenue • Chino, CA 91710-5231
Phone: (909) 465-5528 • Fax: (909) 465-5529 • www.creativebussales.com

Please note:

MBTA / CalACT Cooperative Bid requires a 1.5% procurement fee per unit purchased. Creative Bus Sales will invoice, collect and remit this fee to CalACT. In addition, if the City is not a current member of CalACT you must become a member in order to utilize this procurement.

Please contact Jacklyn Montgomery to be approved for purchasing of this contract and to become a member if required.

Please Contact:

Jacklyn Montgomery Phone: 916-920-8018
Toll Free: 1-800-422-5228 jacklyn@calact.org

Creative Bus Sales, Inc.



Don White
Contract & Transit Sales

**CalACT/MBTA Cooperative Purchase - Bus Equipment Specification
Class E – Ford F-550 Chassis**

Ford F-550, 19,500 GVWR	6.7 Liter Powerstroke Diesel	Automatic Transmission
225 Amp Alternator	Hubodometer	Tire Valve Extensions
Spare Tire – Shipped Loose	Rear Help Bumper w/Hawkeye	As-Built Wiring Diagram
Wiring Diagram on Electrical Panel	Wiring Color & Function Coded	Packard Electrical Connectors
Gateway ILIS w/Fast Idle	LED Exterior Lighting	Daytime Running Lights
Stainless Slide-Out Battery Tray	Battery Disconnect Switch	(2) Batteries
Battery Door Locking Latch	Battery Cable Diagram on Door	Transmission Temp Gauge
Engine Hour Meter	Three Body Grounds	Back-Up Alarm
Frame Corrosion Protection	One-Piece Roof	Stainless Steel Exterior Screws
Docket 90 Seat Covering	Flameblocker Seat Protection	USR Seatbelts
(2) 24" Seatbelt Extenders	Seat Grab Handle	Aisle Side Armrests
Mid-High Back Passenger Seats	High Back Reclining Driver Seat	¾" Exterior Grade Plywood
Coved Flooring	Altro Flooring	Altro Step Edges
Standee Line	Electric Entry Door	Entry Door Key Lock
Entry Door – Park Interlock	Accessible Door – Door Header	Driver Running Board
Driver Entry Grab Handle	Dual Entry Door Grabrails	Overhead Grabrails
Driver Modesty Panel	Plexiglass Upper Modesty Panel	FRP Ceiling/Walls
Fixed Rear Streetside Window	LED Emergency Exit Lights	Insulated Front Cap
Full Undercoating	Steel Wheelwells	Front Mudflaps
70,000 BTU Rear A/C	65,000 BTU Rear Heater	(2) Heater Turn Valves
Silicone Heater Hoses	Braun or Ricon Wheelchair Lift	Dual Lift Doors w/Windows
(2) Wheelchair Restraints	Q'Straint or Surelock	Storage Box for Tiedowns
Web Cutter	Torso Pad	Recessed Front Cap
10lb Fire Extinguisher/Reflectors	16 Unit First Aid Kit	B & R Electric Mirrors
B & R Passenger View Mirror	(6) Interior Lights	Streetside Exhaust
Two-Way Radio Prep	Operations Manual	Blood Borne Pathogen kit
Drivers Coat Hook	Tiedown Training Manual	Chassis – No Tow
ADA Decals	All White Exterior Paint	Recessed Front Exterior Lighting
11" Exterior Step Height	Full PDI Before Delivery	Full Tank of Fuel
4-Wheel Alignment	Headlight Adjustment	Weight Cert/DMV

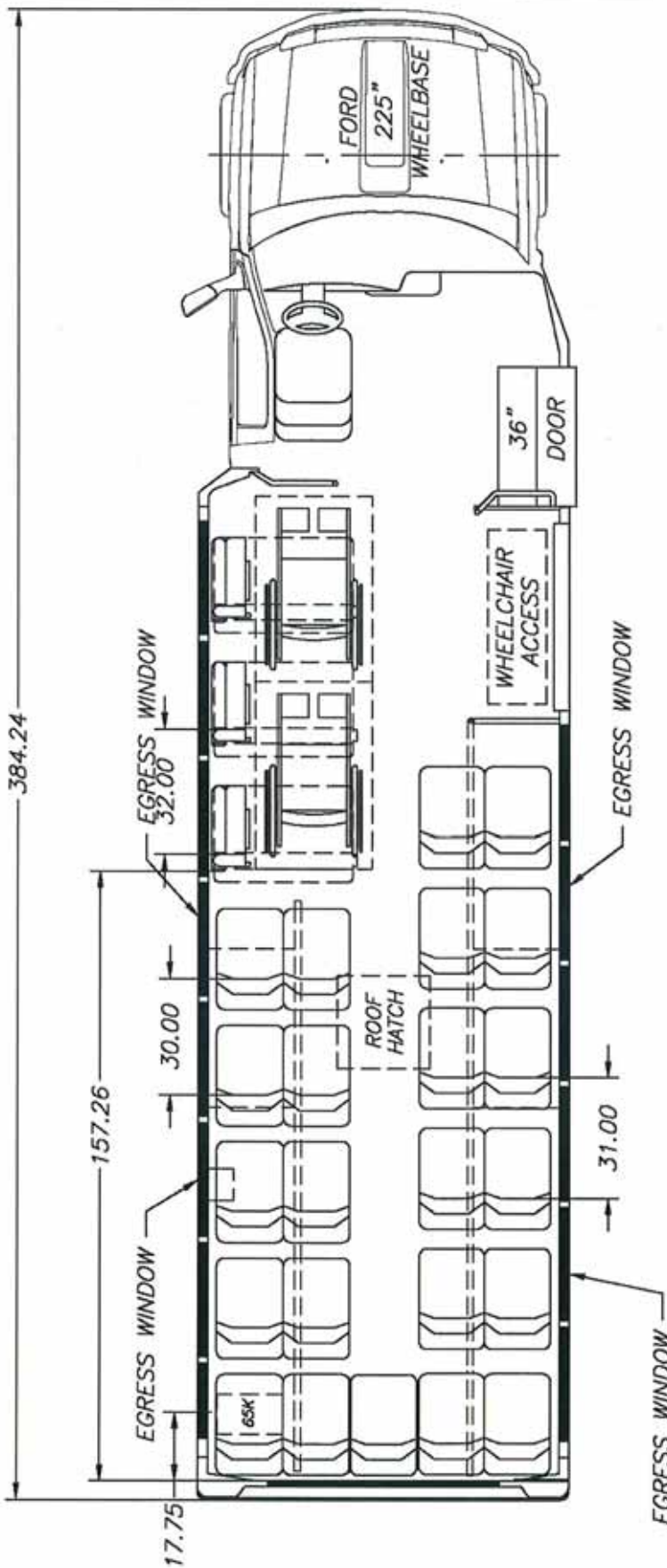

Eldorado National
 — a THOR company —
 1655 WALL STREET
 SALINA, KS. 67401

TITLE:
 AERO ELITE FORD 320 F550
 36" ENTRY DOOR / WC DOOR (FRONT)

UNIT NUMBER
 AEF3214-SM04

PAGE
 1 of 1

DO NOT SCALE DRAWING	DRAWING INFORMATION	REV.	BY	DATE	RELEASE TO PRODUCTION	DESCRIPTION
THIS DRAWING IS THE PROPERTY OF EL DORADO NATIONAL COMPANY, A THOR INDUSTRIES COMPANY AND IS NOT TO BE DUPLICATED OR USED IN ANY WAY DETRIMENTAL TO THEIR BEST INTEREST.	DRAWN: MILLER					
	DATE: 7/1/10					
	SCALE: 1/42					
TOLERANCE UNLESS SPECIFIED						
SEAT SPACING ± 1.0 (SEAT SPACING NOT TO BE LESS THAN 28.5")						
RESTRAINTS ± 1.0 (W/C POSITIONS NOT TO BE SMALLER THAN 30 X 48)						
			JPM	7/1/10		

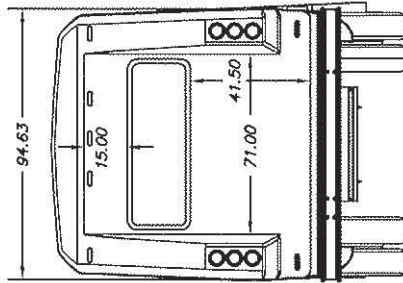
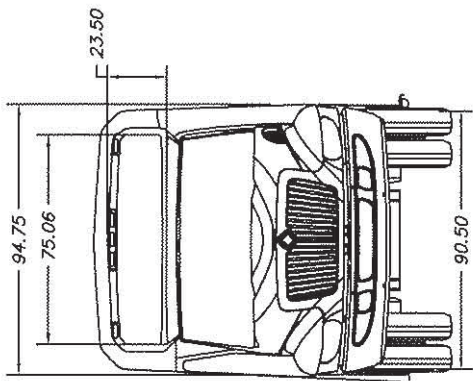

NOTE: OVERALL HEIGHT MAY VARY DUE TO SPRING PKG
OPTIONS AND DOES NOT REFLECT ROOF HATCH.



— a THOR company —
1655 WALL STREET
SALINA, KS. 67401

TITLE:
ELEVATION VIEWS, AERO ELITE 320
36" ENTRY DOOR / WC DOOR (REAR)
MATERIAL SPEC:

PART NUMBER
ELEV3208
PAGE
1 OF 1

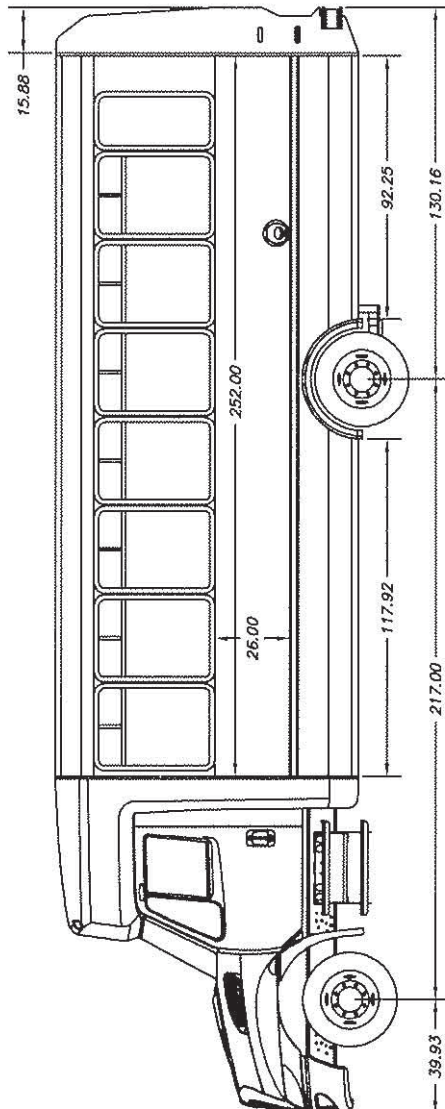
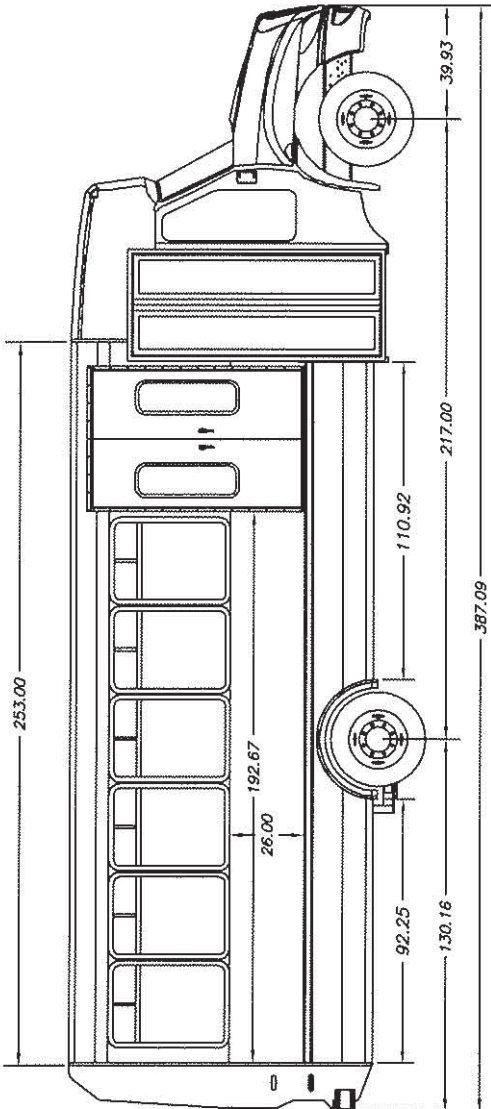

CUSTOMER APPROVAL: _____ DATE: _____
DEALER APPROVAL: _____ DATE: _____
MANUFACTURER APPROVAL: _____ DATE: _____

PAINT #1: CODE: _____
PAINT #2: CODE: _____
PAINT #3: CODE: _____
PAINT #4: CODE: _____

FOR DETAILED OR COMPLEX SCHEMES USE ADDITIONAL PAGE

RESOLUTION NO. 11-xxx

A RESOLUTION OF THE CITY COUNCIL OF THE CITY OF PASO ROBLES
APPROVING PURCHASE OF A NEW TRANSIT VEHICLE

WHEREAS, the city has been granted funds through the State's Public Transportation Modernization, Improvement and Service Enhancement Account (PTMISEA) for the purchase of a new transit bus, and

WHEREAS, the City has previously purchased transit buses through the State contract, and

WHEREAS, City staff has identified the bus model available through the State-approved purchasing consortium which would meet the City's current transit needs most cost-effectively as the Ford F-550 cutaway vehicle with El Dorado body, at a cost of approximately \$128,000;

NOW THEREFORE BE IT RESOLVED that the City Council of the City of El Paso de Robles does hereby approve the purchase of the new transit bus.

PASSED AND ADOPTED by the City Council of the City of El Paso de Robles this 6th day of December, 2011 by the following vote:

AYES:
NOES:
ABSTAIN:
ABSENT:

Duane Picanco, Mayor

ATTEST:

Caryn Jackson, Deputy City Clerk